

DIGI-BEE +

Automation Adaptor

**Installation and Users Manual
(Including Logic-Lab *Plus* Software)**

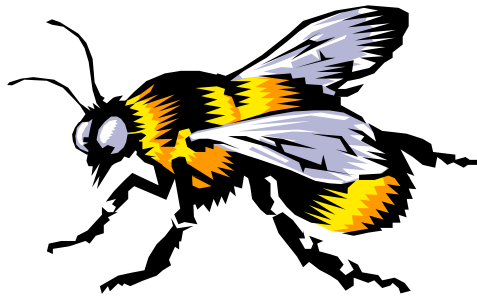

Available from PC Control Ltd
www.pc-control.co.uk

Contents

- 1 Introduction
- 2 Hardware Installation
- 3 Logic-Lab Application Software
 - 3.1 Overview
 - 3.2 Logic-Lab *Plus* Main Screen
 - 3.3 Save and Restore Configurations
- 4 Connecting to Digi-Bee+
- 5 Connector Pinouts
- 6 Writing Your Own Software to Use Digi-Bee+
 - 6.1 Using Digi-Bee+ with visual Basic
 - 6.2 Using Digi-Bee+ with visual C++
- 7 Minimum PC System Requirements

1. Introduction

The DIGI-BEE+ is a versatile USB adaptor, which allows the PC user to explore the world of real time control and automation. It is a tool, which is attractive to both the novice and experienced user.

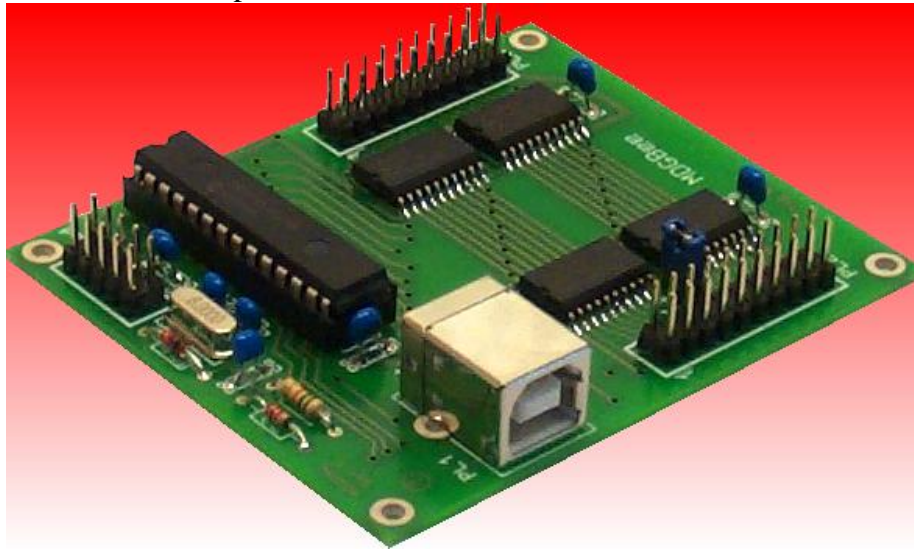

For the absolute beginner it can be used straight from the box as a flexible controller for a wide range of projects. The beginner can take advantage of the ease of connectivity of USB, making connection to the PC simple. The included Logic-Lab *Plus* application software allows the beginner to quickly create elaborate controls without any need for prior programming knowledge or PLC techniques.

For the intermediate user a DLL is provided to allow the programmer to construct their own software applications to take advantage of the DIGI-BEE+ hardware using some very simple library functions which avoids the need to know details of USB communication protocols etc..

2 Hardware Installation

Simply connect the DIGI-BEE+ to any available USB port (*This will require a standard USB cable*). Although it will operate from bus powered hubs it is recommended that you connect it to a primary USB socket or a self powered hub. This allows DIGI-BEE+ to take full advantage of the available 500mA from such a connection. Bus powered hubs are limited to 100mA. Windows operating system will automatically detect and install the appropriate device drivers. The DIGI-BEE+ is regarded by Windows as a standard HID (Human Interface Device) which makes it very easy to install.

3. Logic-Lab Plus Application Software

3.1 Overview

Digi-Bee+ is designed to allow the PC user to implement a real world control system based on reading both analogue and digital input signals and setting digital output signals. However, any control system needs logic to determine which outputs to turn on or off based on the current state of the inputs. This is where Logic-Lab Plus is used. It forms the logical bridge between inputs and outputs connected to the Digi-Bee+. Operating in a manner similar to a PLC system it repeatedly carries out the following three functions...

Read all inputs – Calculate new outputs – Set all outputs

Logic-Lab Plus allows the second function “calculate new outputs” to be specified in terms of traditional logic functions which is described more fully below. It also allows the speed at which the above control loop is run to be specified. This can be important since operating too slowly can miss transitions on some inputs and create too great a time lag to setting the corresponding outputs. Similarly operating too quickly can unnecessarily slow down the operation of the PC.

3.2 Logic-Lab Plus Main Screen

Lets look at the main areas of the LogicLab Plus screen and what they do. The “Input/Output mimic” area (bottom right) shows the current status of the digital inputs and outputs to the Digi-Bee+.

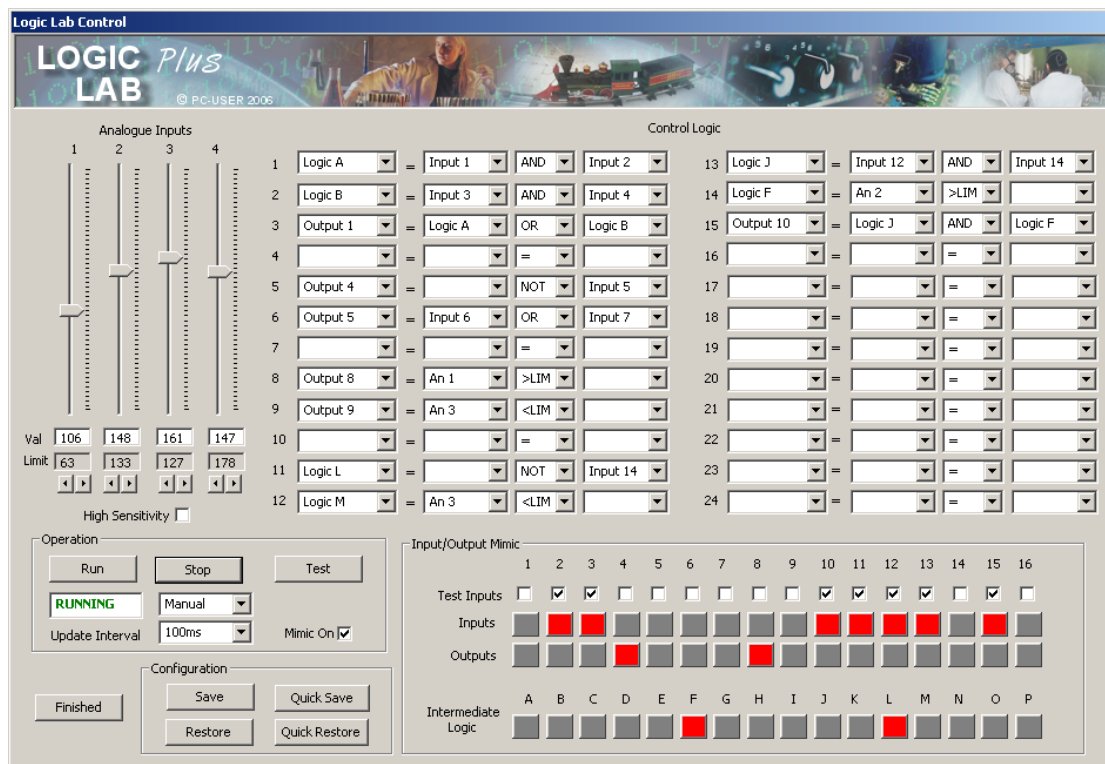

When an indicator lamp is red the logic input is at ‘1’ (i.e. high or +5v) and when it is grey it is at logic ‘0’ (i.e. low or 0v). There is a separate lamp for each of the 16 inputs and each of 16 outputs. There are also 16 lamps for the status of a group

of internal logic values labelled A-P. The use of this internal logic will become apparent as we examine the other logic functions below, but they are also represented by red for '1' and grey for '0'. At the top of the mimic area there are a row of 16 tick boxes labelled "Test Inputs". These allow you to "Test" your logic without actually supplying signals to the DigiBee+ inputs. When in "manual mode" (discussed later) ticking the box represents the corresponding input being on (i.e. logic '1', +5v).

The analogue inputs are represented both numerically and graphically on the top left of the main display. As the voltages appearing at each of the 4 analogue inputs vary, the height of the 4 vertical sliders varies accordingly. The analogue levels are digitised into 255 levels (i.e. 8 bits) with the exact value of the level shown numerically in the "Val" box immediately below it's corresponding slider. The box below each "Val" box is the "Limit" box which allows a limit, or threshold to be set for each analogue input (discussed later).

The operation area contains controls that allow you to specify how the system will actually run. Pressing the "RUN" button will cause continuous execution of the functions described above (i.e. Read all inputs – Calculate new outputs – Set all outputs). Pressing "STOP" halts this process. The time interval at which this loop is executed can be specified using the "Update Interval" selection box. This will allow time intervals from 50ms to 5 seconds to be selected. This should be chosen to reflect the nature of the changes of the inputs and the desired response time of the outputs to these changes. *Remember that this is intended for real world control and not much can happen in 50ms when considering activation of solenoids, switches and motors etc.*

The right hand side of the operation area is devoted to testing and mimic display settings. The system can operate in two modes, namely "Manual" and "Automatic". In automatic mode the system will read the actual inputs from the Digi-Bee+ and set the actual outputs on the Digi-Bee+. In Manual mode the inputs will be read from the current selection of tick boxes in the mimic area and from the analogue levels specified by moving the sliders. (to move the sliders simply click and hold on the mouse left button while over a slider and move up or down to the desired value/position). Manual mode allows you to test your logic without having to generate real signals into the Digi-Bee+. Pressing the "Test" button while in manual mode causes one execution of the loop...

Read all inputs – Calculate new outputs – Set all outputs.

The "Mimic On" tick box will cause all of the screen indicator lamps to follow the current state of the inputs and outputs whether they are real world from the Digi-Bee+ or tick boxes in "Test" mode. Although the "Mimic On" setting is generally left 'on' there are times when it is advantageous to disable this facility. This would be when you are running in automatic mode at , perhaps, the highest update rate and your PC is not the fastest on the planet, or just running too many other programs at the same time. i.e. it reduces the processing requirements of the PC to leave the mimic off.

The main area of the screen is dedicated to specifying the logical relationship between inputs and outputs. It consists of 24 boolean logic equations. Each of these equations can be configured to use any input, output or intermediate logic value with a selectable logic function linking them. Please note that you do not need to specify all 24 equations to use this system. You only specify as many as you need and leave the rest blank.

For example: Equation 1 can be specified as...

$$\text{Output1} = \text{Input1 AND Input2}$$

If the system is then started by pressing the “RUN” button, output 1 will only turn on when both input 1 AND input 2 are on. In a similar way the function “AND” can be changed to “OR” or “NOT”. Note that when the function is “NOT” the second element of the equation is ignored... for example

$$\text{Output1} = \text{Input1 NOT Input2}$$

In this case whenever input 2 is ON , output 1 is OFF and vice versa. Input 1 is ignored. It is good practice to set the first input element to blank in this situation just to make the equation more readable i.e. it is better specified as...

$$\text{Output1} = \quad \text{NOT Input2}$$

Up to 24 equations of this type can be specified and all of them will be “calculated” when the system is “Running”. There is no restriction on having just one equation setting a given output. For example you could specify equation 1 as

$$\text{Output1} = \text{Input1 and Input2}$$

and then have equation 7 as

$$\text{Output1} = \text{Input11 OR Input12}$$

When it comes to calculation time both equations will be evaluated but the later one will have precedence. i.e. the equations are calculated in their numerical order (1-24) and the last equation to set a given output will be the one which is used. Note that although the setting for an output may change between equations during the calculation phase, this is not reflected in the actual outputs of the DigiBee+. All calculations (1-24) are completed before any outputs are set.

Note that when using the analogue inputs as part of logic calculations they only have two possible functions. i.e. greater or less than the specified limit. The specified limit is the numerical box below the corresponding analogue slider. These limits may be edited to whatever you require as part of your control system. To edit these values use the arrow controls immediately beneath the limit boxes. For example...

$$\text{Output4} = \text{An1} > \text{LIM}$$

This would turn output 4 whenever the voltage on analogue input 1 is greater than the limit typed into the limit box.

Note that specifying a logic equation not suitable for analogue inputs (eg $\text{Output1} = \text{An1 AND Input2}$) will result in no action when running.

Although the above gives a very flexible method of determining outputs based on inputs, it can be rather limiting in its extent. This is why we have intermediate logic values A-P. These are in no way related to any real world input or output but allow multiple levels of logic to be created between the actual inputs and outputs. For example suppose you wanted to have output 1 turn on only when all four inputs 1,2,3 and 4 are on. This would be a 4 way “AND” function. Since our equations are only designed for two elements we need to use the intermediate logic as follows....

1. $\text{LogicA} = \text{Input1 AND Input2}$
2. $\text{LogicB} = \text{Input3 AND Input4}$
3. $\text{Output1} = \text{LogicA AND LogicB}$

The above three equations would provide the necessary 4 way “AND” function. This technique can be extended to more complex designs involving any combination of AND, OR and NOT over multiple levels. In constructing multiple level logic

designs always be aware of the order in which the equations are calculated (i.e. 1 to 24) ensuring that all “lower level” functions are calculated first.

While this degree of flexibility allows for a wide selection of control logic scenarios, it is not, and is not meant to be, capable of every possible set of logic.

3.3 Save and Restore Configurations

Once you have your system logic equations specified, they may be stored for later retrieval using the “Save” and “Restore” buttons. This follows conventional windows techniques for naming files and should be familiar. The “Quick Save” and “Quick Restore” is a useful convenience for those (like me) who often don’t want, or need, to specify a file name every time you want to save a configuration before closing the application. Pressing “Quick Save” simply saves the current configuration to a file called “current” with “Quick Restore” retrieving the configuration from this same file.

4. Connecting to Digi-Bee+

Two 20 way headers are provided for making digital connections to the Digi-Bee+. And one 10 way header provides for making the analogue connections. PL2 has 16 digital inputs, two grounds (0v) and two +5v supplies. PL3 has 16 digital outputs and 4 grounds (0v). PL4 has 4 analogue inputs and 4 grounds(0v).

Digi-Bee+ digital inputs and outputs are standard CMOS 5v digital logic compatible. The actual devices on the DigiBee+ board to which both inputs and outputs are connected are 74HC573 latches. It should be noted that the 5v supply available on the input connector (PL2) pins 9 and 10 is derived from the raw USB connector supply and should be treated with some care. It is intended to provide a relatively small amount of current to be used, for example, in “pull up” functions for attaching switches (as shown below).

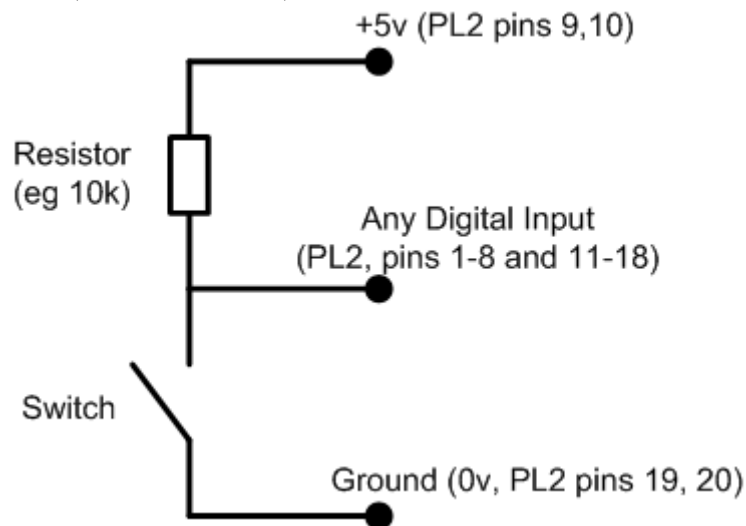

It should not be used to power large electrical circuits. It is recommended to keep current usage on this supply to below 100mA. If this supply is not needed on your input connection then the jumper on the Digi-Bee+ (labelled “5v Link”) should be removed as a safety precaution. This would then leave the pins 9 and 10 disconnected from Digi-Bee+ internal circuitry and the USB 5v supply.

The external circuitry to which these inputs and outputs are connected is, obviously, beyond the scope of this manual, but to assist in determining electrical compatibility and suitability to application, the data sheet for the output devices on the Digi-Bee+ is included on the installation disk. The input and output characteristics of these devices such as current source/sink capacity (approx 25mA per connection), switching speed etc.. etc.. are fully detailed in the data sheet. However, the following guidelines may be useful as a set of tips for the beginner.

1. Always ensure you have a good 0v (ground) connection between the Digi-Bee+ and your own electronics. This is why 2 pins have been devoted to GND on the input connector (PL2) and 4 pins on the output connector (PL3).
2. Make sure the current requirements of the devices you are connecting to can be provided by the Digi-Bee+ 74HC573 output devices.
3. A standard 20 way ribbon cable assembly with IDC sockets is the recommended way of connecting to Digi-Bee+. If you are connecting to your own electronics board then why not fit an identical 20 way header to your board allowing you to use one of the cheap and plentiful ribbon cable assemblies available from most electronics stores.
4. If you need to switch inductive loads such as motors or solenoids consider purchasing the “Bee-Driver” from www.pc-user.co.uk, which converts the Digi-Bee+ output connector (PL2) into 14 high voltage switching outputs with voltage spike protection, or simply construct your own using devices such as the ULN2003 transistor array driver available from most electronics suppliers. With this type of conversion it is then very easy to scale up the power handling potential of the Digi-Bee+ to unlimited amounts using relays which can then be “driven” directly.

Connecting analogue inputs to Digi-Bee+ is also very easy requiring only that you provide a voltage within the operating range of 0 to 5v max. The analogue input signals are strictly unipolar, i.e. they must always be positive with respect to ground. The analogue inputs are connected via PL4 which is a 10 way header. Again, like the digital connections, this is most easily done by using a standard 10 way ribbon cable assembly. The pinout of this connector shown below is arranged to alternate between signal and ground. It is good practice to use the separate ground connection for each of the 4 analogue inputs to avoid any problems with “crosstalk”.

The analogue voltages applied to these pins will be converted by the DigiBee processor to a digital number in the range 0-255 (i.e. 8-bit conversion). This corresponds to the voltage range 0-5v. If your voltages are always within a smaller range, say 0-2v then you can take advantage of the DigiBee+'s increased sensitivity option. To achieve this a separate reference voltage can be applied to specify the range. Already fitted on-board the Digi-Bee+ is a separate 2.4v voltage reference (provided by resistor R2 and Zener Diode D1). This can be used as the voltage range specifier simply by ticking the box on LogicLab Plus labelled “High Sensitivity”. With this box ticked the 0-255 numerical range for the A/D conversions will now be over the voltage range 0-2.4v rather than 0-5v. This means that, for example, an analogue voltage of 1.2v applied to any of the analogue inputs will be converted to the

number 128 (i.e. half full scale). This effectively improves the resolution of the system within the voltage range of interest.

The voltage reference used is brought out to connector PL4 Pin3 in case the user would like to supply their own reference voltage from an external source. However, please note that you must first remove the Zener diode D1, and possibly R2, before any such connection is made. This would require soldering. In normal circumstances this pin should be left unconnected.

5 Connector Pinouts

Pinout of Connectors (PL2 and PL3)

Pin	PL2	PL3
1	Digital Input 1	Digital Output 1
2	Digital Input 2	Digital Output 2
3	Digital Input 3	Digital Output 3
4	Digital Input 4	Digital Output 4
5	Digital Input 5	Digital Output 5
6	Digital Input 6	Digital Output 6
7	Digital Input 7	Digital Output 7
8	Digital Input 8	Digital Output 8
9	+5v (from USB via link)	Digital Output 9
10	+5v (from USB via link)	Digital Output 10
11	Digital Input 9	Digital Output 11
12	Digital Input 10	Digital Output 12
13	Digital Input 11	Digital Output 13
14	Digital Input 12	Digital Output 14
15	Digital Input 13	Digital Output 15
16	Digital Input 14	Digital Output 16
17	Digital Input 15	GND
18	Digital Input 16	GND
19	GND	GND
20	GND	GND

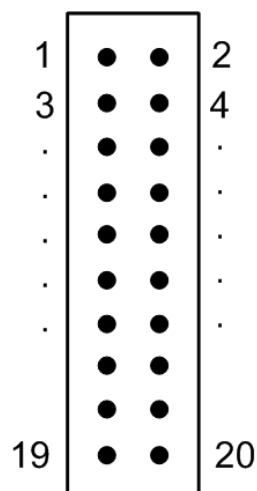

PL2, PL3
Pin Arrangement

Note: Pin1 on both connectors is labelled on the actual Digi-Bee+ board

Pinout of Connector PL4

Pin	Description
1	Analogue Input 4
2	GND
3	Optional Voltage Reference
4	GND
5	Analogue Input 3
6	GND
7	Analogue Input 2
8	GND
9	Analogue Input 1
10	GND

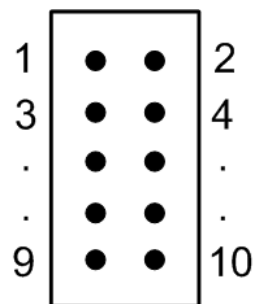

PL4
Pin Arrangement

Note: Pin1 is labelled on the actual Digi-Bee+ board

6. Writing your own software for Digi-Bee+

To use Digi-Bee+ straight from the box does not require any programming other than entering your control logic details into Logic-Lab *Plus*. However, if you prefer to design your own software then the following information will be of use.

Provided with Digi-Bee+ is a DLL (dynamic link library) called “dgb.dll”. This encapsulates the functions used by Logic-Lab *Plus* in communicating with Digi-Bee+ across the USB interface into five simple functions easily understood and used in custom software. Although the DLL was written in ‘C’ it can be used (called) by programs written in a number of popular languages, the most popular of which is BASIC (Visual BASIC). Described below are the techniques to use the DLL in Visual Basic and C++. If you program in another language please refer to your compiler manual on the details of calling a C++ library function, which will be very similar to the techniques described below.

6.1 Using DigiBee+ with Visual Basic.

Using Digi-Bee+ with your own programs written in visual basic is very simple. At the head of your program, before using any of the Digi-Bee+ functions, you must make the following declarations...

Declare Function InitDgb Lib "dgb.dll" () As Boolean

Declare Function SetOutputs Lib "dgb.dll" (ByVal outputs As Integer) As Boolean

Declare Function ReadInputs Lib "dgb.dll" (ByRef inputs As Integer) As Boolean

Declare Function ReadAnalogueInputs Lib "dgb.dll" (ByRef aip1 As Integer, ByRef aip2 As Integer, ByRef aip3 As Integer, ByRef aip4 As Integer) As Boolean

Declare Function SetSensitivity Lib "dgb.dll" (ByVal HighNorm As Integer) As Boolean

These provide sufficient information for your compiler to determine the correct way to use the functions contained within the DLL. You should also ensure that you copy the dgb.dll file from the installation disk to your c:\windows\system32 directory so that your compiler and programs can find it.

Before using any of the input or output functions you must first initialise the Digi-Bee+ using the initialise function as follows...

InitDgb()

There are no parameters required for this function call. Once initialised you can then use any of the other functions anywhere in your program. To set the outputs simply pass the integer value of the on/off pattern required. For example ...

SetOutputs(5)

will turn on outputs 1 and 3, since in binary the value 5 is 000000000000101.

To read the current state of the digital inputs simply pass an integer variable to the ReadInputs() function and use its value after the call. For example if inputs 2 and 4 are on, then the call...

ReadInputs(inputval)

will result in the integer “inputval” containing the value 10.

This is 0000000000001010 in binary.

To read the current values of the 4 analogue inputs pass 4 variables by reference to the ReadAnalogueInputs function...

ReadAnalogueInputs(aip1, aip2, aip3, aip4)

... which will result in the digitised amplitude of the 4 voltage levels on the 4 analogue inputs being returned in the supplied variables aip1 – 4. If , for example, the voltages on the 4 analogue inputs happen to be 1.0v, 2.0v, 2.5v and 3.75v respectively, then the above function call will result in the following values in the 4 variables.....

aip1	aip2	aip3	aip4
51,	102,	128,	196

This assumes a “normal” sensitivity setting

To set the sensitivity to other than 0-5v use the SetSensitivity function...

SetSensitivity(1)	sets high sensitivity based on current voltage reference
SetSensitivity(0)	sets normal sensitivity based on 0-5v

In the above example if the following function call had been made prior to the ReadAnalogueInputs() function....

SetSensitivity(1);

Then the resulting values returned in a1 – a4 would be approximately double (subject to the maximum of 255). This assumes that the on-board voltage reference of 2.4v was used.

What could be simpler.....

As a guide, the source code to a fully working Visual Basic program is contained on the installation CD. This is in the VBdigi directory. It was written using Microsoft Visual Studio and contains the complete workspace for this environment. This allows you to immediately get started editing and running a working visual basic program for the DigiBee+. If you don't have “visual studio” you can still get most of the required information by cutting and pasting code from the main program in the file Form1.vb which can even be opened in a simple text editor such as notepad.

6.3 Using DigiBee+ with Visual C++

Ignoring some of the formalities in the construction of a Visual C++ program for the windows environment the techniques in using “dgb.dll” consists of four main tasks....

Loading the DLL into memory

Before any functions within the DLL can be used it is necessary to instruct windows to load it into memory. This is done by calling the LoadLibrary() function. i.e.

```
.....  
HINSTANCE DgbHandle; // declaration of variable to hold the handle to the dll  
.....  
DgbHandle = LoadLibrary(“dgb.dll”); // load the dll into memory and return handle
```

The declaration of the variable DgbHandle used to store the handle to a DLL , uses a built in type definition which is called HINSTANCE in this particular ‘C’ compiler, but you should use the appropriate one defined in your own compiler for this purpose.

The LoadLibrary() function returns a handle to the DLL if the load is successful otherwise NULL. Ideally your own program should check for a NULL returned and give an error message. Make sure the function parameter is the full pathlist to where you copied the dgb.dll file from the installation CD.

Get the addresses of the functions within the DLL

Using the DLL handle returned above you can now obtain pointers to the functions within the DLL. Using the following

```
TypeInitDgb           InitDgb;  
TypeSetOutputs        SetOutputs;  
TypeReadInputs        ReadInputs;  
TypeReadAnalogueInputs ReadAnalogueInputs;  
TypeSetSensitivity     SetSensitivity  
  
.....  
InitDgb = (Type InitDgb)GetProcAddress( DgbHandle, " InitDgb ");  
  
SetOutputs=(TypeSetOutputs)GetProcAddress(DgbHandle, "SetOutputs");  
  
ReadInputs=(TypeReadInputs)GetProcAddress(DgbHandle, "ReadInputs");  
  
ReadAnalogueInputs=(TypeReadAnalogueInputs)GetProcAddress(DgbHandle,  
"ReadAnalogueInputs");  
  
SetSensitivity=(TypeSetSensitivity)GetProcAddress(DgbHandle, "SetSensitivity");  
  
.....
```

The TypeInitDgb and TypeSetOutputs type definitions are contained in the header file “dg.h” and defines the correct type of function pointer to reference the DLL function. This file is included in the DLL directory on the installation disk. dg.h should be included in your own source file eg.

```
.....  
#include “dg.h”  
.....
```

The call to GetProcAddress() returns a pointer to this function if found within the DLL otherwise NULL. Once the functions pointers have been obtained in this way the internal functions within the DLL are simply accessed like ordinary function calls e.g.

```
.....  
InitDgb ();  
SetOutputs(0x00001234);  
ReadInputs(&inputvalue);  
ReadAnalogueInputs(&AnIP1, &AnIP2, &AnIP3, &AnIP4);  
SetSensitivity(1);  
.....
```

Initialising The DLL

Once the addresses of the DLL functions are obtained as above the remaining functions required to use them are very simple. The first step is to initialise the DLL using....

```
int status;  
.....  
status = InitDgb();
```

Your program should check to see if a value of ‘1’ has been returned by InitDgb (). A value of ‘0’ indicates an error. e.g. Digi-Bee not connected etc...

Using the SetOutputs() Function

This simply applies the pattern of 1’s and 0’s of the 16 bit parameter directly to the outputs. For example: to create a pattern of alternate on and off over all outputs use..

```
SetOutputs(0x5555);           // hexadecimal number
```

Or to turn on just output 1 only, use ...

```
SetOutputs(0x0001);         // hexadecimal number
```

etc.....

More generally.....

```
integer bits;  
.....  
bits = 0x1234;             // hexadecimal number  
SetOutputs(bits);  
.....
```

This example will turn on outputs 13, 10, 6, 5 and 3.

i.e. the least significant bit of each parameter corresponding to the lowest numbered output .

Using the ReadInputs() Function

This will read the pattern of 1's and 0's currently on the Digi-Bee inputs directly to the 16 bit parameter supplied. For example: if inputs 1, 3 and 5 are on the following call.....

```
ReadInputs(&inputval);           // inputval previously declared as integer
```

Will result in the variable `inputval` containing the value 0x0015 (hexadecimal)

Using the ReadAnalogueInputs() Function

Making a call to this function will result in the supplied parameters containing a number in the range 0-255 corresponding to the current voltage appearing on each of the 4 input. For example if the 4 analogue inputs have the following voltages applied to them

A1	A2	A3	A4
1.0v,	2.0v,	2.5v,	3.85v

then this call...

```
ReadAnalogueInputs( &a1, &a2, &a3, &a4);
```

Will result in the passed variables having the following values

a1	a2	a3	a4
51,	102,	128,	196

This assumes normal sensitivity setting.

Using the SetSensitivity() Function

In the above example if the following function call had been made prior to the ReadAnalogueInputs() function....

```
SetSensitivity(1);
```

Then the resulting values returned in a1 – a4 would be approximately double (subject to the maximum of 255). This assumes that the on-board voltage reference of 2.4v was used.

Although this only gives a glimpse of the possibilities of writing your own programs, it should be apparent that the use of the DLL functions greatly simplifies this process. It frees the programmer from the task of getting to know the fine details of programming USB interface communications and lets him concentrate on the main function of reading inputs and setting outputs.

7. Minimum PC System Requirements

Digi-Bee+ and Logic-Lab *Plus* software do not require a high spec PC for correct operation, but the following system is suggested as a sensible Minimum

Processor	500MHz Pentium
Memory	64MB
HDD	10MB free space required
Screen Resolution	1024x768 (256 colours)
Interface	One free USB socket (1.0 or 2.0)
Operating System	Windows 2000, XP or Vista

WARNING: The Digi-Bee+ adaptor board is intended for standard 5 volt digital signals and analogue voltages up to 5v. It should not be connected directly to mains voltages under any circumstances.

Terms of Use for all Goods Supplied

Definitions

'Supplier' shall mean PC Control Ltd.

'Buyer' shall mean the person, company or any other body that purchases or agrees to purchase Goods.

'Goods' shall mean all goods and services which the Buyer agrees to buy from the Supplier including replacements for defective Goods, hardware, documentation and software products licensed for use by the Buyer.

Use of the Goods in any way by the Buyer constitutes acceptance of these terms and conditions.

Terms and Conditions

1. The Goods are intended to be part of the buyer's own design of apparatus and not a finished product in their own right.
2. The Goods supplied are not to be used in any design where there is a risk, however small, either directly or indirectly, of death or personal injury.
3. The Buyer will be responsible for ensuring the fitness for purpose of the Goods for the Buyer's application.
4. To the extent permitted by law, the Supplier accepts no liability whatsoever or howsoever arising in respect of loss, damage or expense arising from errors in information or advice provided whether or not due to the Supplier's negligence or that of its employees, agents or sub-contractors save for any loss or damage arising from death or personal injury.
5. To the extent permitted by law, the Supplier shall not be liable to the Buyer by reason of any representation (unless fraudulent), or any implied warranty, condition or other term, or any duty at common law, or under the express terms of any Contract with the Buyer, for any indirect, special or unforeseen loss or damage (whether for loss of profit or otherwise), costs, expenses or other claims for compensation whatsoever (whether caused by the negligence of the Supplier, its employees or agents or otherwise) which arise out of or in connection with the supply of the Goods or their use or resale by the Buyer.
6. The entire liability of the Supplier under or in connection with the Contract with the Buyer shall not exceed the price of the Goods except as expressly provided in these terms and conditions.
7. These terms are an important part of the full terms and conditions of business as published on the website at www.pc-control.co.uk/general-terms.htm which also apply.

If you cannot agree to the terms and conditions of use of the DigiBee+ then you should return the DigiBee+ to the supplier within 7 days of receipt to receive a refund. Your use of the board or the associated software in any way whatsoever will be regarded as an acceptance of these terms and conditions.